

Instruction Manual EN 1298-IM-EN

The ALTO Ultima® Tower is certified to BS EN 1004:2004

3T - Through The Trapdoor Method

Assembly Guide Using **5 Rung** Starter Frames



Introduction

Please read these instructions carefully and ensure that you fully understand all of the information contained herein. All of the information in this document is vital for the safe utilisation of your ALTO Ultima® Tower.

All Alto Access products are professional quality engineered equipment designed primarily with safety in mind and meet or exceed all standards, recommendations and guidelines. Used properly, Alto access equipment will keep you safe when working at height.

This manual contains all of the information necessary to correctly assemble your ALTO Ultima® mobile access tower and incorporates all of the requirements of the PASMA 3T method of assembly as endorsed by the HSE.

This manual should be used in conjunction with your Risk Assessment and Method Statement and in line with the Work at Height Regulations 2005 which place an obligation on employers to eliminate or minimise risks. This manual must be made available to the user/assembler at all pertinent times.

Only competent and qualified personnel should undertake erection, dismantling or alteration, organisation, planning or supervision of mobile access towers. In the case of any doubt, sufficient relevant additional training must be given beforehand to ensure safe use. For further information on the use of mobile access towers consult PASMA (www.pasma.co.uk; Tel +44 (0) 845 230 4041). For any additional technical information or specific advice please contact the manufacturer: Lakeside Industries Limited Tel: +44 1527 500577 or Email: sales@altoaccess.com.

Certifications

The ALTO Ultima® Tower is a mobile access tower certified to EN 1004 Class 4. If the application is outside the scope of EN 1004, reference should be made to EN 1139 to ensure that the configuration of the equipment meets the relevant requirements. This tower is manufactured in our ISO 9001 accredited facility. This manual complies with EN 1298-IM-EN.

Maximum Safe Working Loads

The safe working load of the tower is 2,500kg including its own weight. The maximum safe working load of any individual platform is 324 kg evenly distributed. If the tower is to be used in an application outside the scope of EN1004, contact your supplier or the manufacturer, Lakeside Industries Limited, for advice on loadings. Tel: +44 1527 500577 or Email: sales@altoaccess.com.

Inspection Care & Maintenance

Alto Access equipment is designed and manufactured to the highest standards in the industry and is stronger, more robust and safer than any comparable competitor product. Properly cared for, it will give a long and productive service life.

- The equipment should be inspected and maintained as outlined in the “ALTO Ultima® Tower Inspection Procedures”. A free downloadable copy is available at www.altoaccess.com/downloads
- Equipment should always be inspected before and after each use.
- Whilst Alto Access equipment is extremely robust, care should be exercised in loading, transporting and handling components to avoid damage or injury to either the equipment or persons.
- Repairs should only be carried out by Lakeside Industries Limited or their authorised repairers.
- In case of any doubt as to the integrity of any items of Alto Access equipment, the part should be withdrawn from use, quarantined and subject to detailed examination to determine whether repair or replacement is required. If returned to the factory, Lakeside Industries Limited will provide a free of charge evaluation of any damaged components.

Safety

Check that all of the necessary components and equipment for the particular tower configuration to be built are on site, undamaged and functioning correctly. Damaged/incorrect components must not be used.

- Check that the surface on which the tower is to be located is capable of supporting the tower and its payload.
- The safe working load of the tower is 2,500kg including its own weight. The maximum safe working load of any individual platform is 324 kg evenly distributed.
- If the tower is to be used in an application outside the scope of EN1004, contact your supplier or the manufacturer: Lakeside Industries Limited, for advice on loadings. Tel: +44 1527 500577 or Email: sales@altoaccess.com.
- Towers **must always** be climbed from the inside using the built in ladders (or Alto stair units if applicable). If the work carried out from the tower requires frequent carrying of equipment and materials up or down the tower, an Alto stair tower should be used in preference to a ladderspan tower.
- The tower must be levelled when erected using the adjustable jack or castor legs.
- Two or more persons are required for the safe erection and dismantling of a tower.

- It is recommended that the tower be tied in when left unattended.
- Always comply with the Work at Height Regulations 2005 when erecting, dismantling & using the tower.
- When lifting components, always use reliable lifting equipment and fastening methods and always lift from within the footprint of the tower structure to prevent risk of the tower overturning.
- See "*Moving the Tower*" below for safety guidelines affecting the relocation of the tower.
- Beware live electrical installations, cables, moving machinery or other obstructions when erecting, dismantling or using the tower. The tower is a conductive metallic structure.
- The maximum safe lateral force for a freestanding ALTO Ultima® tower is 30kg.
- Do not use boxes, ladders or other items to gain additional height.
- Do not stand on guard rails for any reason.
- If the tower is to be used in connection with hoisting arrangements, this is outside the scope of EN1004 and requires specific advice from the manufacturer to ensure safety.
- Contact the manufacturer Lakeside Industries Limited for advice on loadings Tel: +44 1527 500577 or Email: sales@altoaccess.com.
- Fit guard rails to every platforms.
- Fit toe boards to all working platforms.
- Intermediate (rest) platforms are installed every 2m.
- The tower is not designed to be sheeted. Sheeting massively increases wind loads on the structure. If sheeting is to be attached, contact the manufacturer Lakeside Industries Limited for advice on loadings Tel: +44 1527 500577 or Email: sales@altoaccess.com.
- The tower is not designed to be lifted or suspended.
- Every erected tower must be inspected at least every seven days and any tower which has been left unattended should be inspected before use to ensure that:
 - 1 no components have been removed or relocated incorrectly;
 - 2 the tower is still vertical; and
 - 3 no environmental or other factors have arisen which will influence safe use of the tower.
- Unattended towers should be tied in to a rigid structure.
- Stabilisers or outriggers and ballast shall always be fitted when specified.
- Where there is insufficient clearance to fit the specified stabilisers, contact your supplier or the manufacturer for specific advice. Where ballast or kentledge is used, it must be of solid material, placed on a platform on the lowest rung of the tower and secured against unauthorised removal.

Wind Speeds

Persons using or responsible for towers must beware of the effect of wind on the structure. Wherever possible, as a precaution, it is advisable to tie the tower in to a rigid structure if it is to be used where it is exposed to potential windy conditions. Users should beware the potential tunnelling effect of open ended or unclad buildings and narrow openings between buildings. We recommend that the use of the tower is discontinued in conditions where the wind speed is above 17mph (force 4).

WIND DESCRIPTION	BEAUFORT SCALE	AVERAGE SPEED	INFORMATION
Medium Breeze	4	13-17 mph	Safe to work on tower.
Strong Breeze	6	25-31 mph	Tie the tower to a solid structure. Do not work on tower.
Gale Force	8	39-46 mph	Towers must be dismantled. Towers must not be assembled.

Erecting & Dismantling the Tower

All Alto towers must be built and dismantled in accordance with the step by step instructions in the following pages corresponding to the particular tower configuration involved and having regard to the working at height regulations and Health & Safety legislation.

Moving the Tower

Before moving the tower, its overall height should be reduced to 4m working platform height or less. No persons, tools, equipment or materials shall be permitted to remain on the tower when it is being moved.

The tower should only be moved by pushing it by the lowest frames.

When moving the tower users are to be particularly careful of the following:

- Obstructions, moving machinery or electrical cables and equipment
- Not to move the tower in wind speeds of 18mph (force 5) or above
- The effect of rough, uneven or sloping ground on the stability of the tower
- Locking and unlocking the castors to allow and prevent the tower moving at appropriate times
- After completing the movement, use a spirit level to ensure that the tower is vertical and safely supported on an appropriate surface
- After completing the movement check that the tower is correct and complete.

Frames

Frames **must** always be assembled with the offset conical head fitting pointing inwards towards the centre of the tower.

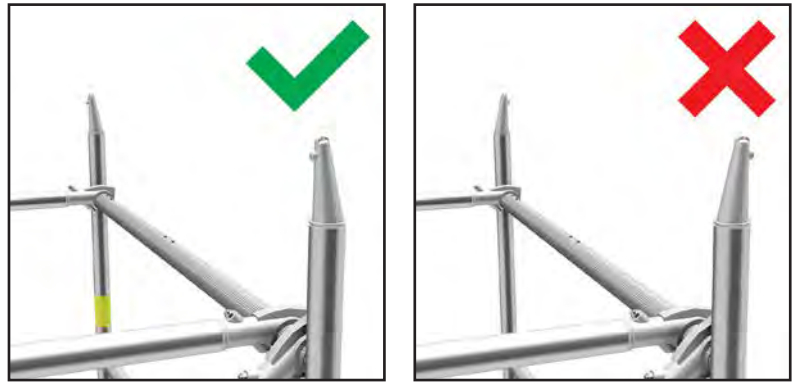

Braces

All braces are fitted with spring loaded pins that automatically lock the brace into position when attached to a tower. Brace hooks **must** be located either over the rung screw heads, between 2 screw heads or between the frame upright and a screw head to prevent lateral movement.

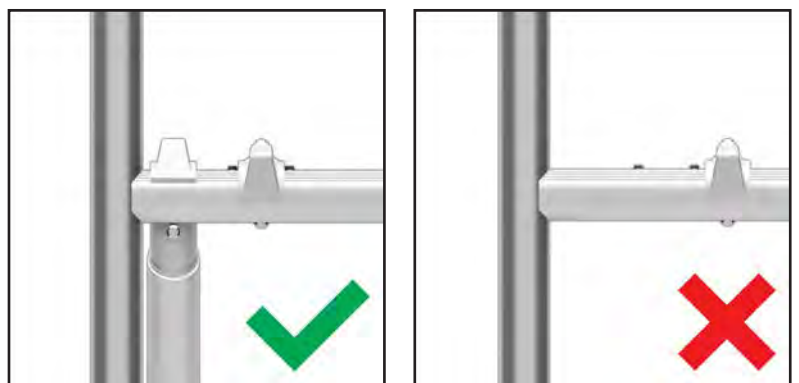

Diagonal braces **must** always be located with the claw opening facing down. Horizontal braces must be located with the claw facing either down (on the rung) or outwards (if on the upright).

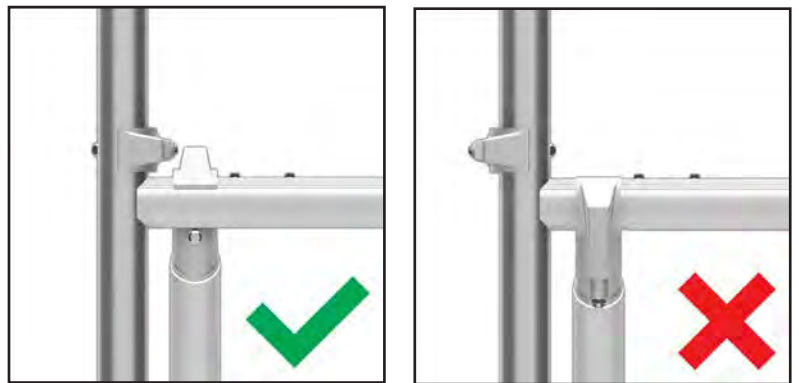

Stabilisers

Stabilisers should always be attached to the tower so as to maximise the base area of the tower structure. Set the stabilisers so they form a square around the tower as per the diagram below. The correct size stabilisers **must** always be used - see component schedule for details.

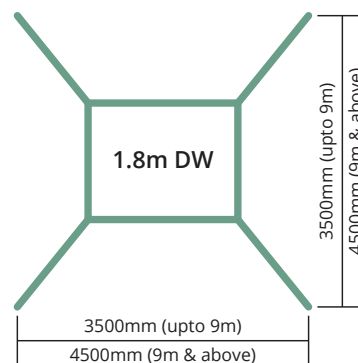

Ultima[®] Anchor Point

The Alto Ultima Anchor Point is an integrated part of an Alto Ultima frame. It is designed for attaching personal protective equipment for preventing and arresting falls from height of a single operative from a tower comprised entirely of Alto Ultima components.

The Alto Ultima Anchor Point is an EN795 certified type A device used to anchor a safety harness, or restraint belt via a lanyard, to prevent the user reaching a position where a fall is possible (restraint). It is not intended for fall arrest unless the lanyard is fitted with an energy absorber conforming to

EN355 connected to the anchor using EN362 connectors (hooks, karabiners etc.) and the operative is wearing a compatible BS EN 361 safety harness and any other relevant PPE.

All testing of anchor points and fall arrest systems is based on a 100kg mass. Users of over 100kg in weight should seek advice as to whether the equipment is suitable for their safe use. Users of over 100kg should seek to limit lanyard length to the shortest possible length to minimise arrest forces to below 6kn.

Read the separate instruction manual before using the Alto Ultima Anchor Point. The use of the device contrary to the manual poses a threat to life.

Ensure that all users have appropriate training and certification before use. Before use – visually inspect the anchor point for the following points:

- Ensure the system has not been modified/tampered with.
- Check the legibility of the product markings
- Visually inspect the anchor point and the frame that it forms part of for physical damage.
- Check for signs that the anchor has been used in a fall arrest event. Typically this will be evidenced by the anchor being bent or showing dents in the inner surface of the anchor.
- Check all components for distortion/dents. Ensure that this does not affect the fitting of the steel anchor plate.
- Check all the steel anchor plate fastenings are tight.
- Check for any general corrosion.

If there are any doubts arising from pre-use inspection, the device must not be used. Report the issues to the equipment supplier.

As part of your risk assessment you **MUST** have in place a rescue plan to deal with any emergency, which



may occur during use. Access to the user - directly or indirectly - and their safe retrieval is of paramount importance, including preparations for dealing with potential Post Fall Suspension Syncope

Ensure that there is sufficient fall clearance below the anchorage connector to arrest a fall before the user strikes the ground or an obstruction. When calculating fall clearance, account for a **MINIMUM** 0.5m safety factor, deceleration distance, user height, maximum deployed length of lanyard/SRL, and all other applicable factors.

3T Method Explained

The “3T” or “through the trapdoor” method is one of the two permitted ways of assembling a tower without the assembler being at risk of falling. This tower is a 3T tower.

Step 1:

As each new level of platform is installed, the operative takes up a working position in the trap door of the platform, standing on the ladder and leaning back against the edge of the trapdoor aperture.

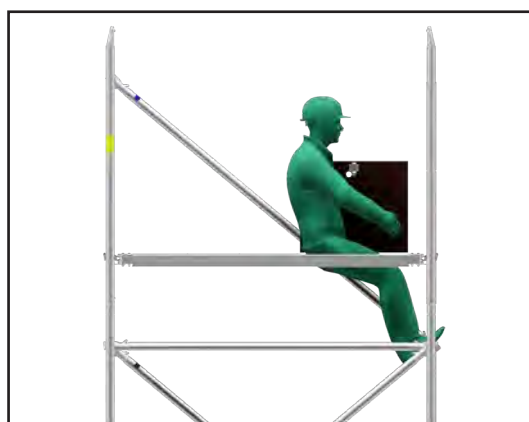

Step 2:

From this position the operative fits the horizontal braces 500mm and 1000mm above the platform level (i.e. on the first and second available rungs). If the far end of the guardrail braces don't fully engage when they are put in place, the operative fully engages it when first climbing up onto the platform. This process ensures that operatives never have to stand on an unguarded platform.

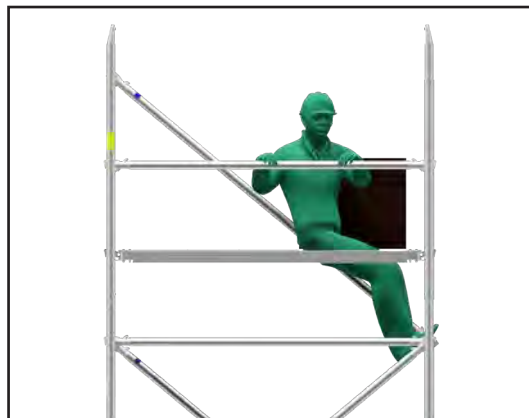

Tying In

Towers must be tied into a suitable rigid structure once they go beyond the freestanding working heights specified in EN 1004 2004 - 8m working platform height outdoors and 12m working platform height indoors - or if the tower is unstable or is in danger of being unstable.

Standard scaffold tubes and fittings can be used with the Alto Access products. Ties should be spaced at no more than 4m intervals. Ties must be rigid and be secured to both frame uprights. For further details regarding tying in, please contact your supplier or the manufacturer: Lakeside Industries Limited.

COMPONENT SCHEDULE

1.8m Long x 1.4m Wide (Double Width) ALTO Ultima® Tower

DOUBLE WIDTH ALTO ULTIMA® TOWER TO BS EN 1004:2004

Using the 3T (Through The Trapdoor) assembly method

CODE	PART DESCRIPTION	Wt	PLATFORM WORKING HEIGHT (m)																				
			INTERNAL & EXTERNAL USE								INTERNAL USE ONLY												
			2.4	2.9	3.4	3.9	4.4	4.9	5.4	5.9	6.4	6.9	7.4	7.9	8.4	8.9	9.4	9.9	10.4	10.9	11.4	11.9	12.4
2238	150mm Dia. Castor Wheel	3.0	4	4	4	4	4	4	4	4	4	4	4	4	4	4	4	4	4	4	4	4	
2240	HD Adj. Leg (silver collar)	1.4	4	4	4	4	4	4	4	4	4	4	4	4	4	4	4	4	4	4	4	4	
2066	HD 1.8m D/W Toeboard	9.9	1	1	1	1	1	1	1	1	1	1	1	1	1	1	1	1	1	1	1	1	
2001	HD 1.4m Base Frame	12.9	1	1	1	1	1	1	1	1	1	1	1	1	1	1	1	1	1	1	1	1	
2212	HD 1.4m 5 Rung Ladder Frame	15.5	1	1	1	1	1	1	1	1	1	1	1	1	1	1	1	1	1	1	1	1	
2301	Ultima® 1.4m 4 Rung Main Frame	11.7			1		1	1	2	1	2	2	3	2	3	4	3	4	4	5	4	5	
2304	Ultima® 1.4m 4 Rung Ladder Frame	14.3			1		1	1	2	1	2	2	3	2	3	4	3	4	4	5	4	5	
2302	Ultima® 1.4m 3 Rung Main Frame	9.0	1		1		1	1	1	1	1	1	1	1	1	1	1	1	1	1	1	1	
2305	Ultima® 1.4m 3 Rung Ladder Frame	11.0	1		1		1	1	1	1	1	1	1	1	1	1	1	1	1	1	1	1	
2303	Ultima® 1.4m 2 Rung Main Frame	6.0	1		1		1	1	1	1	1	1	1	1	1	1	1	1	1	1	1	1	
2306	Ultima® 1.4m 2 Rung Ladder Frame	7.3	1		1		1	1	1	1	1	1	1	1	1	1	1	1	1	1	1	1	
2040	HD 1.8m Brace	2.6	6	8	11	11	11	11	12	15	15	15	16	19	19	19	20	23	23	24	27	27	
2041	HD 2.7m Brace	3.6	2	2	4	2	4	4	4	6	4	6	6	8	6	8	8	10	10	10	12	12	
2080	HD 1.8m x 3 Rung Brace (Blue)	3.2	2	2		4	2	2	2	4	2	2	2	4	2	2	2	4	2	2	4	2	
2043	HD 1.8m Platform	14.3	1	1	1	1	1	1	1	1	1	1	1	1	1	1	1	1	1	1	1	1	
2201	HD 1.8m Trap Platform	15.0	1	1	2	2	2	2	2	3	3	3	3	4	4	4	4	5	5	5	6	6	
2056	HD Small Stabiliser	6.0	4	4	4	4	4	4	4	4	4	4	4	4	4	4	4	4	4	4	4	4	
2057	HD Large Stabiliser	7.8																4	4	4	4	4	
TOTAL SELF WEIGHT OF TOWER (kg)		152	164	193	206	213	223	252	265	272	281	281	311	324	331	340	377	390	397	406	436	449	455
MAX No. WORKING LEVELS		1	1	2	2	2	2	3	3	3	3	3	3	3	3	3	3	3	3	3	3	3	3
BUILD METHOD		A	B	C	D	A	B	C	D	A	B	C	D	A	B	C	D	A	B	C	D	A	B

ASSEMBLY INSTRUCTIONS - All Platform Working Heights

Step 1

Insert the leg & castor assembly into the base of the 5 Rung Base Frame and 5 Rung Ladder Frame. When fully inserted, ensure the spring loaded pin is engaged into the hole in the side of the frames. Ensure all 4 wheels have the brakes applied.

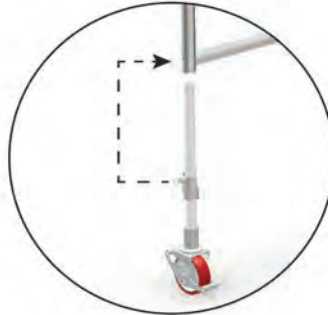

Step 2

Connect 2 horizontal braces to the uprights of the first frame in the area just above the bottom rung. Make sure that the braces are connected from the inside of the tower facing outwards. Make sure that the frame head fittings are pointing inwards into the tower.



Step 3

Connect the 2nd frame to the horizontal braces in the same position that they are located on the first frames. Make sure that the frame head fittings are pointing inwards into the tower.





Step 4

Connect 2 standard diagonal braces to the frames as shown. Keep the diagonal braces as close to the frame uprights as possible. Ensure that they run in opposite directions to each other.



Step 5

Install a trap platform on the 3rd rung up and 4 horizontal braces as guard rails. Clip a 5th horizontal brace on the top rung of the frames, on the opposite side to the guard rails. Using a spirit level, ensure that the framework is completely level by adjusting the legs. Twist the serrated collar above the wheel to adjust up & down.



Step 6

Once the framework is in position and level, connect 4 stabilisers to the corners. Fix the shorter arm to the lowest part of the frame, then connect the longer arm to the upper part, ensuring the foot is firmly placed on the ground. Small vertical adjustments can be made to either arm to guarantee a sturdy placement.

Build Method A 2.4m, 4.4m, 6.4m, 8.4m, 10.4m, 12.4m

Step 7.1

Working from the temporary platform, install a 2 rung frame & a 2 rung ladder frame onto the 5 rung frames. Then, clip onto the top rungs 2 blue diagonal braces. The other end connects to the rung 3 below on the opposite face. Diagonal braces always run parallel to the braces below.

Install another 4 guard rails above the 4 already in place for when the platform is relocated.



Step 7.2

Remove the lower 4 guardrails by either using the 3T method or removing them from the ground. Then relocate the platform to the top rung of the first frames. If a 2.4m tower is being assembled go to Step 10. Working off this new platform position, install a 4 rung main frame and a 4 rung ladder frame. Then clip on 2 standard diagonal braces. The start position of the brace should be on the same rung height as the finishing position from the brace below - running in the same parallel direction.

Proceed to Step 9



Build Method B 2.9m, 4.9m, 6.9m, 8.9m, 10.9m



Step 7.1

Working from the temporary platform, install a 3 rung main frame & a 3 rung ladder frame onto the 5 rung frames. Then, clip onto the top rungs 2 blue diagonal braces. The other end connects to the rung 3 below on the opposite face. Diagonal braces always run parallel to the braces below.



Step 7.2

Lower the platform down to the 2nd rung of the base frames and ensure that there are 4 guardrails installed (on a 2.9m tower, the plain platform is to be used here). Remove the horizontal brace in the middle of the tower on the top rung of the base frames - leaving the horizontal brace on the outside of the tower still installed. Now install a 2nd trap platform 4 rungs above the first one.



Step 7.3

The platform and 4 guardrails at the base can now be removed. Using the 3T method install 4 guardrails to the upper platform. Make sure that there are still 2 horizontal braces at the base of the tower and the 5th rung up on the tower. If a 2.9m tower is being assembled, go to step 10.

Proceed to Step 8

Build Method C 3.4m, 5.4m, 7.4m, 9.4m, 11.4m

Step 7.1

Working from the temporary platform, install a 4 rung main frame & a 4 rung ladder frame onto the first set of 5 rung frames. Then, clip 2 standard diagonal braces on. The start position of the brace should be on the same rung height as the finishing position from the brace below - running in the same parallel direction.



Step 7.2

Install a 2nd platform 4 rungs above the first platform. Using the 3T method install 4 guardrails to the upper platform. If a 3.4m tower is being assembled, go to step 10.

Proceed to Step 8



Build Method D 3.9m, 5.9m, 7.9m, 9.9m, 11.9m



Step 7.1

From the platform, install a 2 rung & 2 rung ladder frame onto the 5 rung frames. Then, clip onto the top rungs 2 blue diagonal braces. The other end connects to the rung 3 below on the opposite face. Diagonal braces always run parallel to the braces below. Now install another 4 guardrails above the 4 already in place for when the platform is relocated.



Step 7.2

Remove the lower 4 guardrails by using the 3T method or uninstalling them from the ground. Relocate the platform to the top rung of the first frames. A temporary platform can be placed on the bottom rung of the tower to help do this. Working off the new upper platform position, install a 3 rung main frame and a 3 rung ladder frame. Clip on 2 more blue diagonal braces.

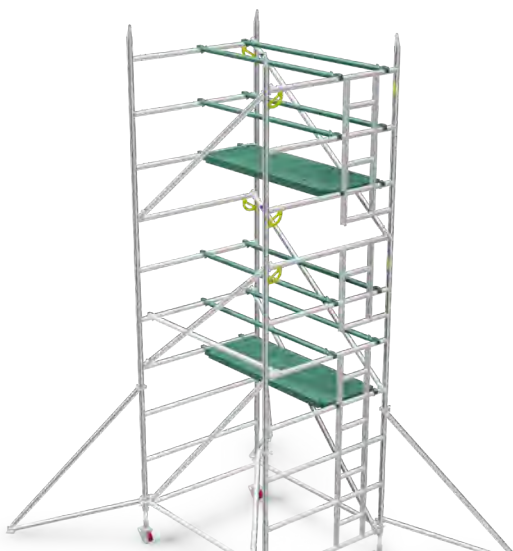

Step 7.3

Lower the uppermost platform down 1 rung and relocate the guardrails into the correct positions using the 3T method. Install another platform 4 rungs above and install 4 guardrails using the 3T method. Remove the temporary platform off the bottom rung of the tower if it was used in step 7.2. If a 3.9m tower is being assembled, go to step 10.

Proceed to Step 8

All Platform Working Heights

Step 8

Working from the top platform, install a 4 rung main frame & a 4 rung ladder frame. Then, clip 2 standard diagonal braces on. The start position of the brace should be on the same rung height as the finishing position from the brace below - running in the same parallel direction.



Step 9

Install a trap platform 4 rungs above the previous platform. Using the 3T method install 4 guardrails to the upper platform.

Now, repeat steps 8 and 9 until the required platform working height is achieved. Once the final step 9 is complete, move to step 10.

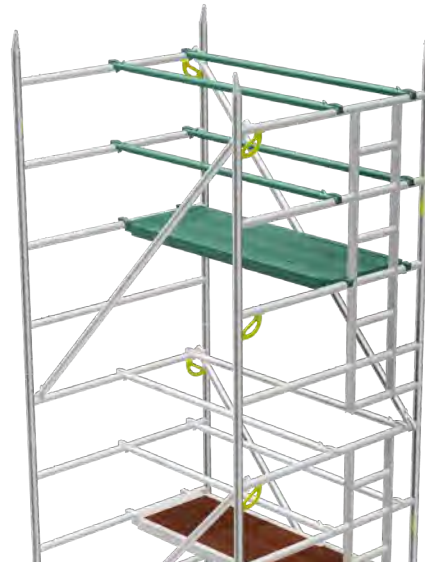

Step 10

Finally, working from the guard railed platform, install a plain platform along side the trap platform and using the 3T method relocate the inner guardrails to the outside face of the tower. Now install a toeboard, ensuring that the sides are hooked securely over the outside edge of both platforms.



DISMANTLING INSTRUCTIONS - All Platform Working Heights



Step 1

The dismantling procedure requires a minimum of 2 operatives to complete the task safely. To start, first remove the aluminium toeboard assembly.



Step 2

Now, relocate the uppermost diagonal braces downwards so the top hook is located on the same rung as the uppermost platform. This can be done by either using one operative on the top platform and one operative on the platform underneath, or by disengaging the top hook then climbing down onto the platform below and disengage the 2nd hook.



Step 3

Next, remove the 4 guardrails. To remove braces or guardrails, first disconnect each brace at the end furthest away from the platform trap door. Then immediately take up the protected position detailed in the 3T method. Whilst standing through the trapdoor as per the 3T method, disconnect the braces completely.

DISMANTLING INSTRUCTIONS - All Platform Working Heights

Step 4

Now, working from the platform below, the upper platform(s) can be removed. Once these are fully removed, the recently relocated diagonal braces can now be taken off. This can be done by one operative from the platform.



Step 5

Now remove the final 2 frames off the top of the tower.

Now repeat steps 2 to 5 until the tower is dismantled or the new platform height is achieved.



Components



2238 - 150mm castor
2240 - HD Adj. Leg



2001 - HD 1.4m Base Frame



2212 - HD 1.4m 5 Rung Ladder Frame



2301 - Ultima® 1.4m Main Frame



2304 - Ultima® 1.4m 4 Rung Ladder Frame



2302 - Ultima® 1.4m 3/4 Frame



2305 - Ultima® 1.4m 3 Rung Ladder Frame



2303 - Ultima® 1.4m 1/2 Frame



2306 - Ultima® 1.4m 2 Rung Ladder Frame



2040 - 1.8m Brace
2041 - 2.7m Brace



2080 - 1.8 x 3 rung Brace (blue)

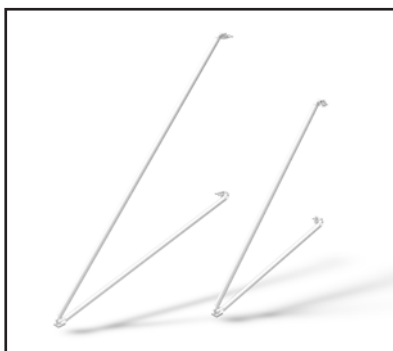

2056 - HD Small Stabiliser
2057 - HD Large Stabiliser



2201 - 1.8m Trap Platform
2043 - 1.8m Plain Platform



2066 - 1.8m D/W Toeboard

THE HEIGHT OF SAFETY

For further information regarding our range of access products and services, please get in touch with us:

Lakeside Industries Ltd
Unit 19 Howard Road, Park Farm Industrial Estate
Redditch, Worcestershire. B98 7SE. UK

t: +44(0)1527 500 577
e: sales@altoaccess.com
w: www.altoaccess.com

 @lakesideindust

 @altotowers

 lakeside-industries-ltd



Manufacturing Member

Lakeside Industries Ltd

Unit 19 Howard Road, Park Farm Industrial Estate, Redditch, Worcestershire. B98 7SE
+44(0)1527 500577 | sales@altoaccess.com | www.altoaccess.com

